

SKYTECH

Model: 1001T/LCD-A

INSTALLATION AND OPERATING INSTRUCTIONS

IF YOU CANNOT READ OR UNDERSTAND THESE INSTALLATION INSTRUCTIONS DO NOT ATTEMPT TO INSTALL OR OPERATE

INTRODUCTION

This remote control system was developed to provide a safe, reliable and user-friendly remote control system for gas heating appliances.

TRANSMITTER

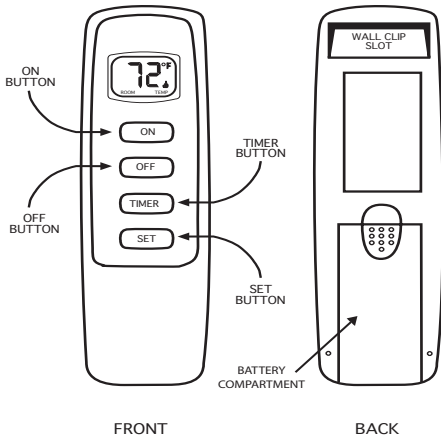

The transmitter operates on (2) 1.5V AAA batteries. It is recommended that ALKALINE batteries always be used for this product. **Be sure the batteries are installed with the (+) and (-) ends facing the correct direction, and are fully charged.**

KEY SETTINGS

1. **ON** --- Turns appliance ON.
2. **OFF** -- Turns appliance OFF.
3. **TIMER** Changes unit from manual mode to timer mode.
4. **SET** -- Adjusts timer setting.

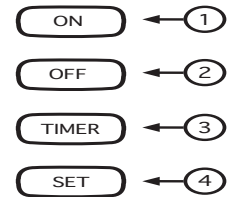

LCD - LIQUID CRYSTAL DISPLAY

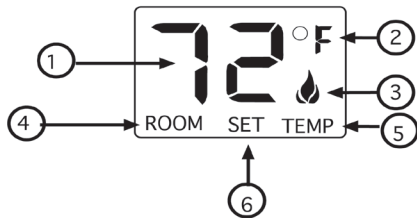

1. Display ----- Indicates current room temperature.
2. Fahrenheit or Celsius Indicates degrees Fahrenheit or Celsius.
3. Flame ----- Indicates appliance is ON.
4. Room ----- Indicates remote is in THERMO mode.
5. Temperature ----- Appears during manual operation.
6. Set ----- Appears when adjusting the desired timer setting.

SETTING °FAHRENHEIT / °CELSIUS SCALE

The factory setting for temperature is °F. To change the displayed temperature scale, press the **ON** and **OFF** keys at the same time. Follow this same procedure to return to °F.

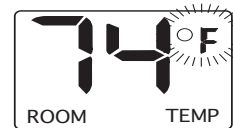

MANUAL FUNCTION

ON OPERATION:

Press the ON key to turn the appliance **ON**. (The flame icon will appear on the LCD screen).

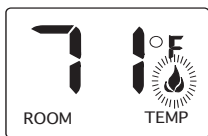

ON MODE

OFF OPERATION:

Press the OFF key to turn the appliance **OFF**. (The flame icon will disappear from the LCD screen).

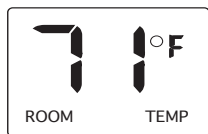

OFF MODE

TIMER FUNCTION

- Press the **ON** button to start the appliance.
- Press the **TIMER** button. The LCD screen will show the word set.
- Press the **SET** button until the desired time is reached (15 min. - 180 min. in 15 minute increments). The max setting time is 3 hours.
- NOTE: The LCD display will flash the set time for 6-seconds, then start the countdown.
- Press the **OFF** button to turn OFF the timer, and the appliance.



SET MODE



COUNT DOWN MODE

TEMPERATURE UPDATING FEATURE

This remote control has a temperature updating feature built into its software. The transmitter reads the room temperature every 2-minutes, then updates the room temperature on the LCD screen.

RECEIVER

Install the 4 AA-size batteries supplied with the unit. It is recommended that ALKALINE batteries always be used for this product. **Be sure the batteries are installed with the (+) and (-) ends facing the correct direction.**

The remote receiver has a 3-position slide switch for selecting the mode of operation **ON/REMOTE/OFF**

- **ON:** will manually turn on appliance.
- **REMOTE:** will allow use of handheld transmitter. If the system does not respond to the transmitter on initial use, check the battery positions in the remote. If that does not work, see the SECURITY CODE section.
- **OFF:** will disable the remote receiver.
- **It is suggested that the slide switch be placed in the OFF position if you will be away from your home for an extended period of time.**

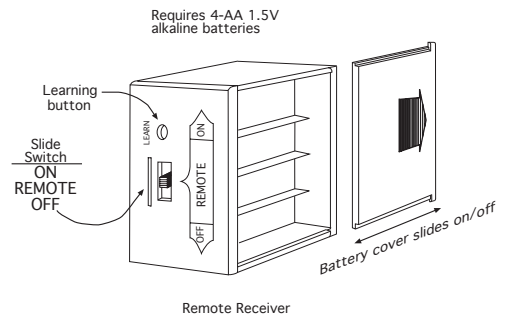

INSTALLATION

The remote receiver can be either wall-mounted in a standard plastic switch box (not metal) or placed on or near the fireplace hearth. Preferably, the remote receiver should be wall-mounted in a plastic switch box, as this will protect its electronic components from the heat produced by the gas appliance. The remote receiver should be kept away from temperatures exceeding 130° F. Battery life is also significantly shortened if batteries are exposed to temperatures 130°F or higher.

Before installation make sure the remote receiver slide switch is in the **OFF** position. After installation be sure that the slide switch is moved to the **REMOTE** position.

WARNING

This remote control system must be installed exactly as outlined in these instructions. Read all instructions completely before attempting installation. Follow instructions carefully during installation. Any modifications of this remote control or any of its components will void the warranty and may pose a fire hazard.

Consult gas appliance manufacturer's instructions and wiring schematics for proper placement of all wires. All electronic modules are to be wired to manufacturer's specifications.

The following wiring diagrams are for illustration purpose only. Follow instructions from manufacturer of gas valve and/or electronic module for correct wiring procedures. Improper installation of electric components can cause damage to electronic module, gas valve and remote receiver.

MOUNTING THE REMOTE RECEIVER

WALL MOUNT

When wall mounting the remote receiver, longer wires (not included) are required to connect to the gas valve or electronic module. These wires must:

- Be at least 18 Gauge (AWG)
- Be no longer than 20-feet
- Have no splices

To attach Cover Plate to Receiver Box:

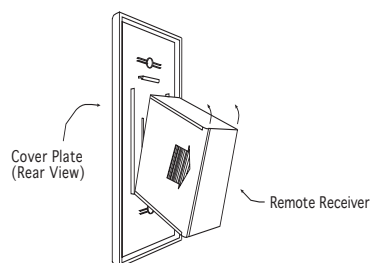

Position the receiver as shown in diagram to the left with lower tab on cover plate inserted into groove of receiver (Ensure the LEARN hole on cover plate properly aligns with remote receiver). Pull receiver up and snap into top tab of cover plate.

Position the cover plate so the word ON is facing up; then, install the remote receiver into the plastic switch-box using the two long screws provided. Push the white button over the receiver slide switch.

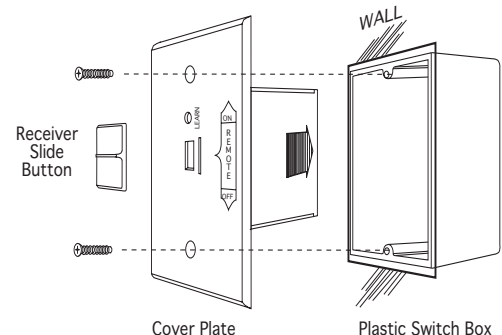

HEARTH MOUNT

- The remote receiver can be placed on the fireplace hearth or under the fireplace behind the control access panel.
- Use the wires attached to the remote receiver to connect to the gas valve or the electric module (piggyback connectors have both male & female terminals for flexibility).
- Be sure that the connectors do not touch each other or other bare metal surfaces: this will cause the appliance to turn on. The connectors may be wrapped with electrical tape to prevent this.

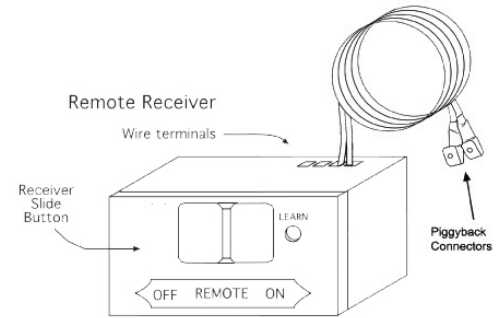

WIRING INSTRUCTIONS

A qualified electrician should install the remote control system.

WIRING MILLIVOLT VALVES

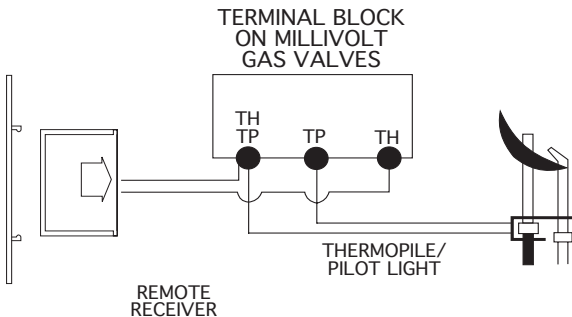

- Connect one wire from the remote receiver to the TH terminal on the gas valve.
- Connect the other wire from the remote receiver to the TH/TP terminal on the gas valve.

MILLIVOLT SYSTEM CHECK

- Ensure that the pilot flame is lit.
- Slide the 3-position button on the remote receiver to the **ON** position. The main gas flame (i.e., the fire) should ignite.
- Slide the button to **OFF**. The main flame should extinguish (the pilot flame will remain on).
- Slide the button to **REMOTE**, then press the **ON** button on the transmitter to change the system to on. The main gas flame should ignite.

WIRING ELECTRONIC SPARK IGNITIONS

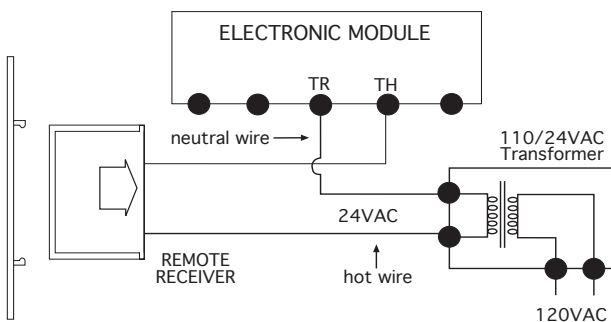

The remote control receiver can be connected, in series, to a 24VAC transformer to the TR (transformer) terminal on the ELECTRONIC MODULE. Connect the hot wire from the 24VAC transformer to either of the wire terminals on the remote receiver. Connect another wire between the other receiver wire terminal and the TH (thermostat) terminal on the ELECTRONIC MODULE.

ELECTRONIC SPARK SYSTEM CHECK

- Slide the 3-position button on the remote receiver to the **ON** position. The spark electrode should begin sparking to ignite the pilot. After the pilot flame is lit, the main gas valve should open and the main gas flame should ignite.
- Slide the button to **OFF**. The main gas flame and pilot flame should both extinguish.
- Slide the button to **REMOTE**, then press the **ON** button on the transmitter to change the system to on. The spark electrode should begin sparking to ignite the pilot. After the pilot is lit, the main gas valve should open and the main gas flame should ignite.

CP (CHILDPROOF) FEATURE

This remote control includes a childproof feature that allows the user to “lock-out” operations from the Transmitter.

- To activate and de-activate the childproof feature, press and hold the **ON** button and the **TIMER** button at the same time for 5-seconds. The letters “CP” will appear in the TEMP frame on the LCD screen when childproof mode is activated.
- “CP” will appear on the LCD screen if any button is pressed while childproof mode is engaged.
- When this mode is engaged, all auto settings go on without interruption (like thermostat). Only manual functions are prevented.

LEARNING TRANSMITTER TO RECEIVER

Each transmitter uses a unique security code. It will be necessary to press the LEARN button on the receiver to accept the transmitter security code upon initial use, if batteries are replaced, or if a replacement transmitter is purchased from your dealer or the factory. In order for the receiver to accept the transmitter security code, be sure the slide button on the receiver is in the REMOTE position; the receiver will not LEARN if the slide switch is in the ON or OFF position. The LEARN button is located on the front face of the receiver; inside the small hole labeled LEARN. Using a small screwdriver or end of a paperclip gently press and release the black LEARN button inside the hole. When you release the LEARN button the receiver will emit an audible "beep". After the receiver emits the beep press the transmitter ON button and release. The receiver will emit several beeps indicating that the transmitter's code has been accepted into the receiver.

NOTE: This receiver can hold up to 3 transmitter codes. This is for the times when a second hand held transmitter or a wall transmitter is required.

COMMUNICATION - SAFETY - TRANSMITTER - (C/S - T/X)

This remote control has a COMMUNICATION –SAFETY function built into its software to ensure the transmitter and receiver are communicating normally.

In all operating modes, the transmitter sends an RF signal every fifteen minutes to the receiver indicating that the transmitter is within the normal operating range of 20-feet. Should the receiver NOT receive this signal, the receiver will begin a 2 hour countdown. If the receiver does not receive a signal from the transmitter in 2 hours, the receiver will shut off the appliance. The receiver will then emit a series of rapid "beeps" for a period of 10 seconds. Then after 10 seconds of rapid beeping, the receiver will continue to emit a single "beep" every 4 seconds until a transmitter **ON**, **OFF** or **MODE** Button is pressed to reset the receiver.

TRANSMITTER WALL CLIP

The transmitter can be hung on a wall using the clip provided.

- Wood - Drill 1/8" pilot holes and install with screws provided.
- Plaster/Wallboard - Drill 1/4" holes, then install with the screws provided.

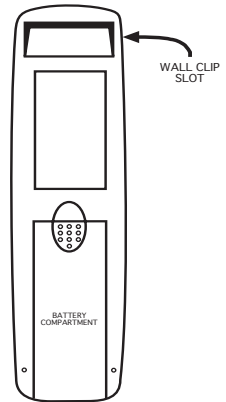
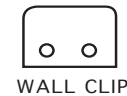

BATTERY LIFE

Life expectancy of the alkaline batteries in the transmitter and receiver should be at least 12 months. Check and replace all batteries:

- Annually.
- When operating range becomes reduced.
- When transmissions are not received by the remote receiver.
- If the remote receiver batteries measure less than 5.3 volts (all four batteries in combination).
- If the hand held transmitter batteries measure less than 2.5 volts (both batteries in combination).

TROUBLE SHOOTING

If you encounter problems with your fireplace system, the problem may be with either the fireplace itself or with this remote. Review the fireplace manufacturer's operation manual to make sure all connections are properly made. Then check the operation of the remote in the following manner:

- Make sure all batteries are correctly installed in the transmitter and receiver. Also check if the batteries are fully charged.
- Check batteries in transmitter to make sure contacts are touching (+) and (-) ends of battery. Bend metal contacts in for tighter fit.
- Ensure receiver and transmitter is within 20 to 25-foot operating range.
- Keep receiver from temperatures exceeding 130° F. Battery life will be shortened if exposed to high temperatures.
- If receiver is installed in a tightly enclosed metal surrounding, the operating distance will be shortened.
- Make sure the hand-held transmitter and remote receiver are communicating properly (See LEARNING TRANSMITTER TO RECEIVER section).

FCC REQUIREMENTS

NOTE: THE MANUFACTURER IS NOT RESPONSIBLE FOR ANY RADIO OR TV INTERFERENCE CAUSED BY UNAUTHORIZED MODIFICATIONS TO THIS EQUIPMENT. SUCH MODIFICATIONS COULD VOID THE USER'S AUTHORITY TO OPERATE THE EQUIPMENT.

FOR TECHNICAL SERVICE, CALL:

U.S. INQUIRIES
 (855) 498-8324 or (260) 459-1703
 For Sales: (888) 672-8929
 WEB SITE: www.skytechpg.com

CANADIAN INQUIRIES
 (877) 472 -3923

MANUFACTURED EXCLUSIVELY FOR SKYTECH II, INC

Limited Lifetime Warranty

SKYTECH warrants the SKYTECH REMOTE CONTROL SYSTEM for a Limited Lifetime of the original owner of this system. This warranty is not transferable to another person it is for the original purchaser of the product.

Should any part fail because of defective workmanship or material from the original date of purchase. SKYTECH will repair or, at SKYTECH option, replace the defective parts.

Replacement parts will be available at no charge for the first (5) five years of this warranty, and will be available at market cost for the Lifetime of the product to that original owner. If SKYTECH does not have the parts for an individual model, then a replacement SYSTEM will be provided. At no charge for the first (5) five years and sold at market cost for the Lifetime of that product to the original owner.

The Owner must provide a bill of sale, cancelled check, or payment record should be kept to verify purchase date and establish warranty period. Travel, diagnostic cost, service labor to repair the defective SYSTEM, and freight charges on warranty parts to and from the factory will be the responsibility of the owner. SKYTECH will not be responsible for labor charges and/or damage incurred in installation, repair, replacement, or for incidental or consequential damages. Batteries and any damage caused by them are not covered by them are not covered by this warranty.

This warranty does not cover claims, which do not involve defective workmanship or materials.

Damage to the SYSTEM caused by accident, misuse, abuse, or installation error, whether performed by a contractor, Service Company, or owner, is not covered by this warranty. Modification of the SKYTECH product will void this warranty.

IN NO EVENT SHALL SKYTECH BE LIABLE FOR INCIDENTAL AND CONSEQUENTIAL INCLUDING THE IMPLIED WARRANTIES OF MERCHANTABILITY AND FITNESS, ARE LIMITED TO THE DURATION OF THIS WRITTEN WARRANTY. THIS WARRANTY SUPERSEDES ALL OTHER ORAL OR WRITTEN WARRANTIES.

Some States do not allow the exclusion or limitation of incidental and consequential damages or limitation on how long an implied warranty lasts, so the above limitation may not apply to you. This warranty gives you specific rights and you may have other rights, which vary from state, province, and nation.

How to Obtain Service:

Contact SKYTECH or your SKYTECH Dealer direct with the following information:

- o Name, Address, Telephone Number of Owner
- o Date of Purchase, Proof of Purchase
- o Model Name, Date Code of Product and any relevant information or circumstances, concerning installation, mode of operation and/or when defect was noted

Warranty claim process will start with all of this information. SKYTECH will reserve the right to physically inspect the product for defects, by authorized representatives.

Print information and detach at dotted line for return to: Skytech, 9230 Conservation Way, Fort Wayne, IN 46809

Telephone: (888) 672-8929

Warranty Information

Purchase Date: _____ Model: _____ Date Code: _____

Purchased From: _____

Customer Name: _____ Phone: _____

Address: _____

City: _____ State/Prov. _____ Zip/Postal Code: _____

Back of Remote Date Code Sample

13	●	1	2	3	4	5	6
14		7	8	9	10	11	12

1-12 is Month Product was Made

13&14 is Year Product was Made

Sample date code is 1311

Please send a Proof of Purchase (original receipt) copy along with your warranty form.

Santa's Helper

Exclusive offer to Skytech Remote Control Owners

This special offer is only provided to customers of Skytech that have purchased a remote control for their Hearth Product. This remote control system can be used for any 120VAC appliance, but perfect your Christmas Tree Lights or any other appliance that is difficult to reach or plug in. Simply plug the receiver into your wall outlet and your appliance into the receiver, push the ON button on the transmitter and you are in business. It's that easy!



The list price of **\$48.00** for the Santa's Helper has been cut almost in half to **\$20.00 USD** for this exclusive offer. Shipping and handling of **\$5.00 USD** should be added. Send us your check, money order or call us with your credit card number, along with the warranty information from your remote control of your Hearth Product. You can also send it via mail, fax, or e-mail.

Skytech Products Group
9230 Conservation Way
Fort Wayne, IN 46809
1-(888) 672-8929
1-(888) 672-8024 Fax
E-mail : order@skytechpg.com